



Instructions for Use

The geko™ device is a neuromuscular electrostimulation medical device and its intended use is:

- To increase blood circulation,
- For the prevention of venous thrombosis,
- For the prevention and treatment of oedema.

The device works by increasing blood circulation by stimulating the common peroneal nerve.

It is to be used on a single patient, in hospital, clinic and home environments. Apply to one or both legs as advised by your Healthcare Professional (e.g. Nurse or Doctor). Patients should be trained in the positioning and operation of the device.

The geko device is intended for up to 24 hours continuous use, until it is no longer needed. It may be removed for short periods of time when washing or having various tests (see warnings and precautions). Each device is single use and should be replaced every 24 hours, the device has an additional 6 hours run time.

Read this document fully before use and use only as instructed. Improper use of this device can be dangerous. Do not switch on unless correctly attached to the patient.

If assistance is required or to report difficulties, unexpected operation or events, contact the manufacturer. Visit the website [gekocodevices.com](https://www.gekocodevices.com) for further advice and usage tips.



geko™ Fitting Instructions



1 Location: The marker line ►►●◄◄ on the geko device should line up with the fibula head, a round lump below the knee on the outside of the lower leg. Ask your healthcare provider if you need help (e.g. nurse or doctor).

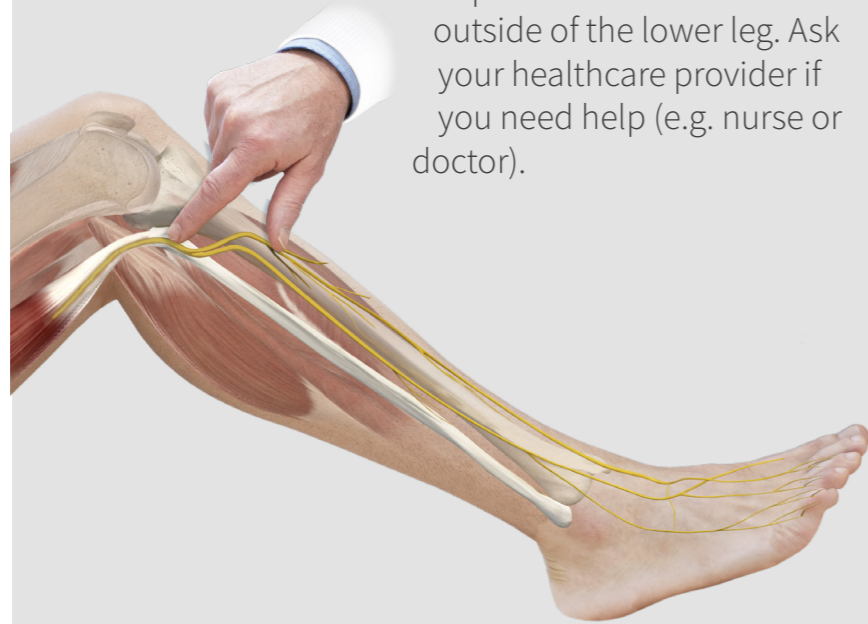

2 Cleaning: It should be applied to clean, dry skin. If there is too much hair in the area it should be removed using trimmers or clippers. Do not shave as this may cause irritation. Wash the skin in the area where the device will be fitted with mild soapy water, rinse, and dry thoroughly; do not apply any moisturiser.



3 Fitting: Remove the film from the geko device and place the marker line ►►●◄◄ over the fibula head (round lump). Attach the short end round the front of the leg and the longer end towards the back of the leg. The geko device should not be loose, peel off one end and tighten if needed. When correctly fitted, the ⊕ button will always be at the front of the leg.

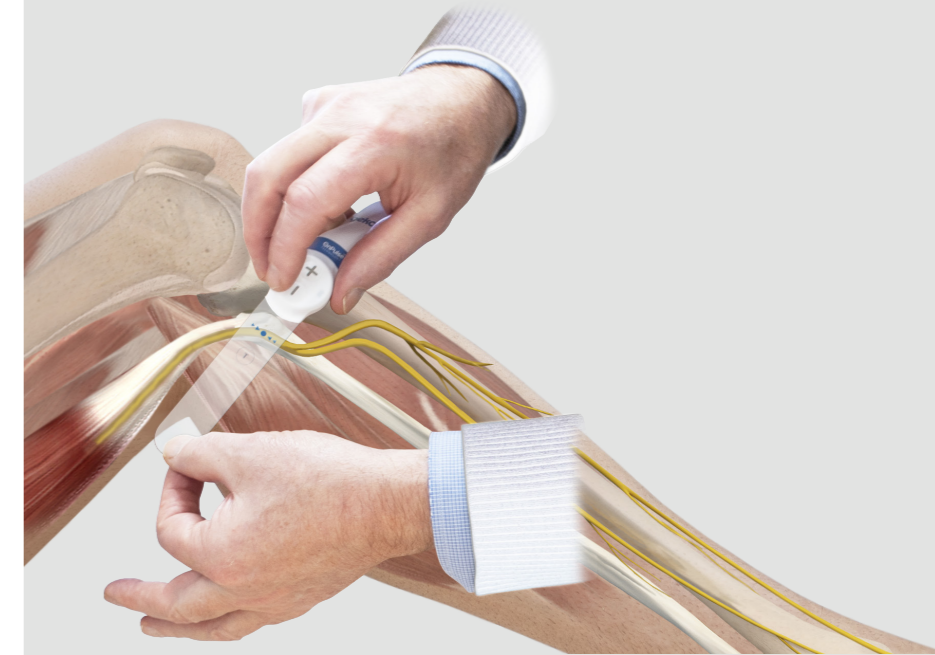

4 Turning On: Use a short press of the ⊕ button (0.5 second) to turn on the device and further short presses to set the appropriate level.



5 Settings: There are 11 levels (indicated by the number of flashes in sequence from the LED while the device is operating). To reduce the levels, one-by-one, use a short press (0.5 second) of the ⊖ button. When working properly the geko device will cause a visible movement of the muscles in the lower leg, moving the foot out and up, which should continue throughout the whole treatment.

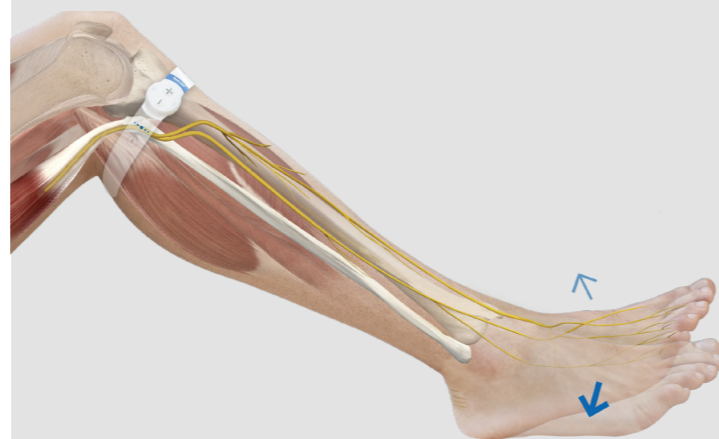

6 Switching Off: To turn it off, hold ⊖ button down for 3 seconds. When the button is held, the light will flash quickly and when turned off the flashing will stop.

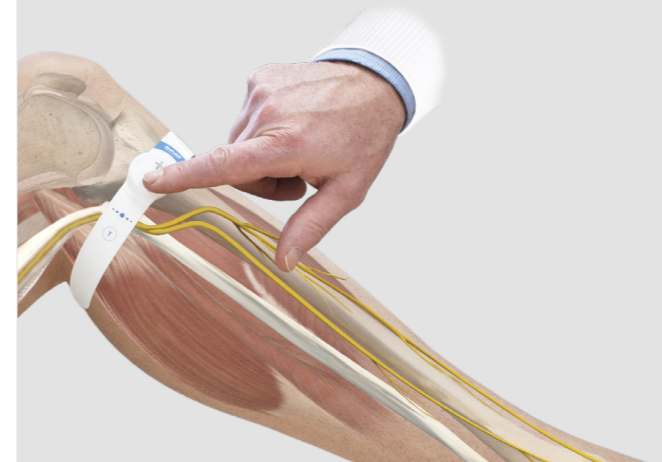

7 Removing: Remove **carefully** in one piece, to avoid damaging the skin.



If stimulation is not achieved the geko device can also be fitted in alternative positions, see the following instructions.

Fibula head:

The fibula head **A** can be felt as a round bony lump on the outside of the leg just below the knee, at the top of the fibula bone **1**.

To find the fibula head start at the front of the kneecap (patella **3**) and feel your way down to the bony lump at top of the tibia bone (tibial tuberosity **2**).

Now feel your way outwards over another bony lump on the tibia (lateral condyle **4**) and then continue outwards and slightly downwards until you find the fibula head, which is larger and more rounded bony lump than the lateral condyle.

Another way to find the fibula head is to place your fingers on the ankle bone, felt on the outside of your ankle (lateral malleolus **5**) which is the lower end of the fibula.

Then run your fingers up the leg in the groove between the calf muscles and the muscles at the front of the leg, until you feel the round bony protrusion that is the fibula head.

You can use an Indelible marker to mark the position of the fibula head.

To help with accurate locations and fitting watch the video at [gekodevices.com](https://www.gekodevices.com).

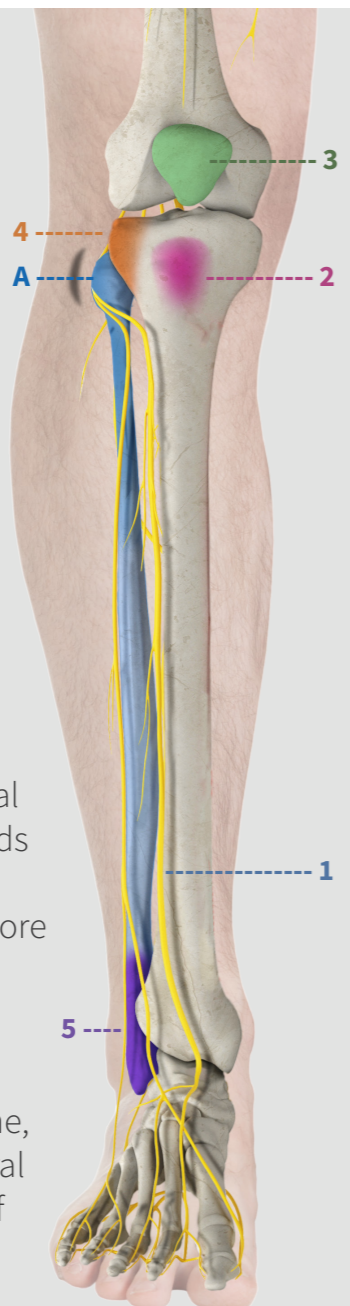

1. Location:

There are three possible locations that will give a successful stimulation of the common peroneal nerve (dorsiflexion). The **A** position aligns with the fibula head, while **B** and **C** are aligned with a prominent lateral hamstring tendon. The reasons for choosing an alternative fitting position include: skin sensitivity or lesions at the other position(s), better stimulation of the nerve because of anatomical variations, better comfort or ease of fitting, or the position of dressings.

2.

Cleaning:

Wash and dry the skin where the device will be fitted.

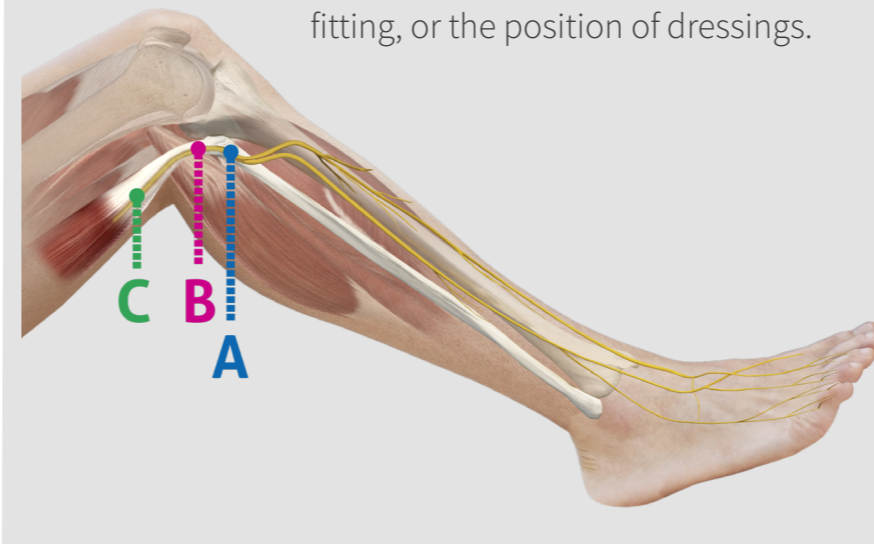

3A. Fitting:

Remove the film from the geko device and place the marker line ►►●◄◄ over the fibula head.

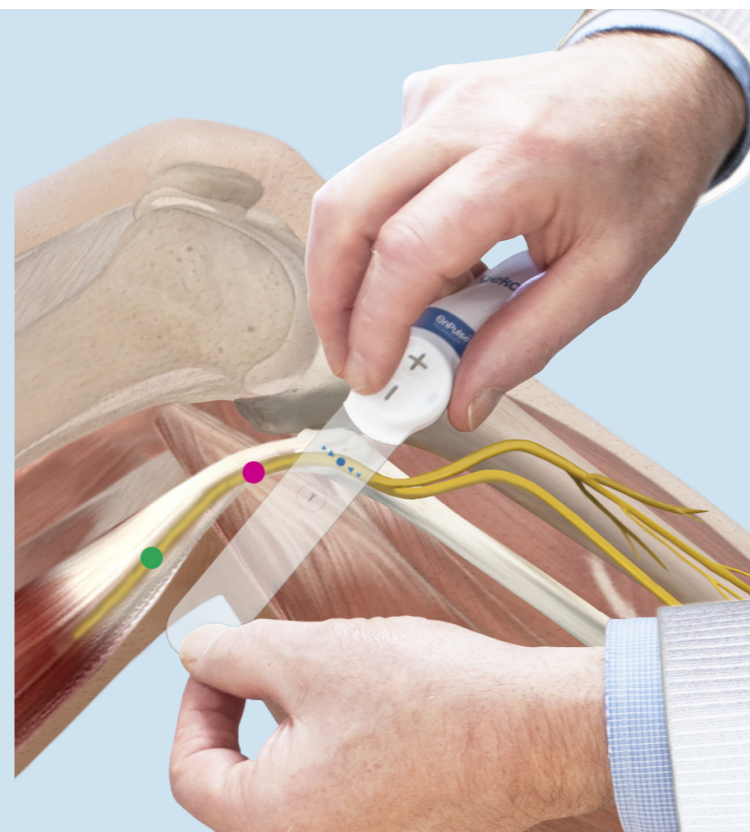

3B.

Fitting:

Place the marker line ►►●◄◄ on the lateral hamstring tendon/outer tendon/biceps femoris tendon below the crease of the knee.

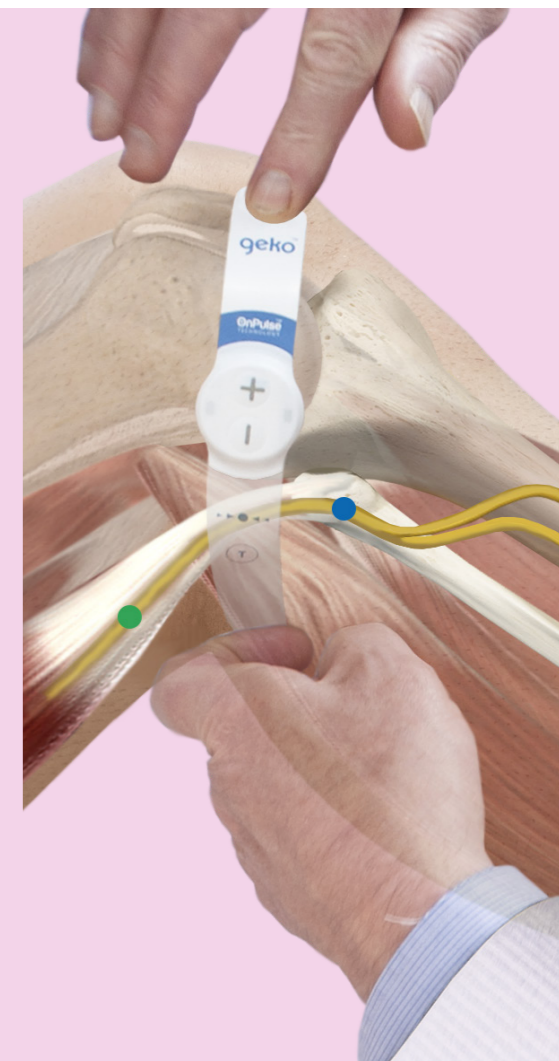

3C.

Fitting:

Place the marker line ►►●◄◄ on the lateral hamstring tendon/outer tendon/biceps femoris tendon just above the crease of the knee.



Side Effects

Skin Inflammation or Irritation:

In some cases, skin inflammation or irritation can develop in the contact area: either remove the device or re-attach in the alternative fitting positions.

If the condition persists or recurs, obtain specialist medical advice before resuming use.

Warnings

Seek specialist medical opinion if the patient is/has:

- implanted electronic devices (e.g. a cardiac pacemaker),
- recently diagnosed or suspected DVT,
- pregnant or breast feeding,
- diagnosed heart condition,
- epilepsy,
- had recent surgery where muscle contractions may disrupt the healing process,
- used the device for 28 consecutive days,

Do not use:

- during any activity in which involuntary muscle contractions may put the user or others at risk of injury (e.g. Driving or operating machinery),
- when bathing or showering – switch off the device and remove temporarily,
- if the device has been worn by another individual – this will carry risk of infection,
- if packaging is open or damaged,
- if device is damaged.

Device should not be used on the following areas of the body:

- head,
- eyes,
- mouth,
- neck (especially the carotid sinus),
- on the chest, upper back or crossing over the heart. This may increase the risk of cardiac fibrillation.

Do not apply over or near the following:

- sore, infected or inflamed areas,
- broken skin or skin eruptions. E.g. phlebitis, thrombophlebitis, varicose veins etc.,
- cancerous lesions.

Do not use in proximity of the following equipment/environments, which could result in the possible degradation of the performance of the geko device:

- short wave/ microwave equipment (i.e. within 1m),
- portable RF communications equipment (including peripherals such as antenna cables and external antennas)(i.e. within 30cm),
- heat sources, such as fires or radiant heaters.

Do not use in oxygen rich environments.

Use on children - the safety of the device has not been tested in children; we do not recommend using the device on children.

Precautions

- Keep out of the reach of children and pets.
- Do not place the geko device in the mouth; it is a choke and potential allergic hazard. If the device or any component is swallowed seek IMMEDIATE medical assistance. Serious harm could be caused if the battery is swallowed.
- No modification of this equipment is allowed.
- Excessive force may damage the device.
- MRI -The device should be removed before the patient undergoes MRI as it contains ferromagnetic components.
- ECG -The device should be switched off during ECG monitoring using leg electrodes as it may interfere with ECG leg electrode signals.

Any serious incident that has occurred in relation to the device should be reported to the manufacturer and the competent authority of the Member State in which the user and/or patient is established.





Storage and operation

When storing the geko device keep it in the protective foil pouch. It can be stored in a temperature range of -25°C to 40°C, but we recommend storing the device up to 30°C.

Classification

The device is internally powered by a non-replaceable CR2032 lithium ion coin cell battery. The battery is intended for continuous operation. Type BF applied part – for direct electrical contact to patient but not direct cardiac application. The whole device is the applied part.

EMC Declaration

Use of the geko device adjacent to other electrical equipment should be avoided because it could result in improper operation. If such use is necessary, the geko device and the other electrical equipment should be observed to verify that they are operating normally. The geko device is certified to EN 60601-1-2:2015 regarding Electromagnetic Compatibility. Medical Electrical Equipment needs special precautions regarding EMC and needs to be put into service according to the EMC information provided on the website gekodevices.com. The geko device may switch off if exposed to high levels of electromagnetic disturbance.

Output Specifications

The device provides square wave, asymmetric, charge balanced stimulation pulses at a rate of 1Hz. The pulses are of a constant current between 27mA and 54mA, and with pulse widths between 35µs and 560µs, according to the stimulation level set. The stimulation intensity increases progressively by increasing the electrical charge in each pulse. There are 11 settings in total. For further information including operating specifications visit the website gekodevices.com. The software revision level is identifiable through the Lot number.

Output waveform

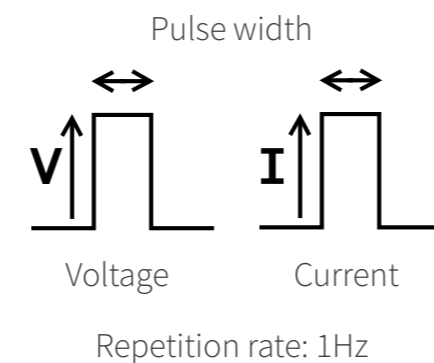



Disposal

The geko device does not contain any toxic or environmentally hazardous materials. After use it may be potentially contaminated or infected because it has been in contact with skin for several hours, and so needs to be disposed of with care. Batteries must be disposed of in accordance with any local legislation. Some hospital and clinics will have specific requirements for disposal of used medical devices. If used at home the geko device may be disposed of in your general waste if regulations permit. For ease of disposal the electrodes may be removed with scissors if necessary. The battery can be removed by breaking open the housing and forcing out. See the website gekodevices.com for guidance. Do not incinerate the device.

EU Authorised Representative



Emergo Europe B.V.,
Westervoortsedijk 60,
6827 AT Arnhem,
The Netherlands

CH Authorised Representative



MedEnvoy Switzerland,
Gotthardstrasse 28,
6302 Zug,
Switzerland.

Firstkind Limited





















Hawk House,
Peregrine Business Park,
Gomm Road,
High Wycombe,
HP13 7DL, United Kingdom,
T: +44 (0)1494 572040.



T-3

Symbols

-  Medical device
-  Type BF applied part
-  Product not manufactured with Latex
-  Single use only – use only on one patient for a single course of treatment
-  Storage and transportation atmospheric pressure range whilst within packaging
-  Lot number
-  Catalogue number
-  Expiry date – do not use after this date
-  Storage and transportation temperature range whilst within packaging
- IP22** Ingress protection rating 22
-  EU Authorised Representative
-  CH Authorised Representative
-  Unique device identifier
-  Storage and transportation humidity range whilst within packaging
-  Manufactured by
-  See Instructions for Use
-  CE Mark of Conformity
-  UKCA Mark of Conformity
-  Importer
-  Do not use if package is damaged